

Speak and Greet Oval Set

Legend:

ST = Straight Track

CT = Curved Track

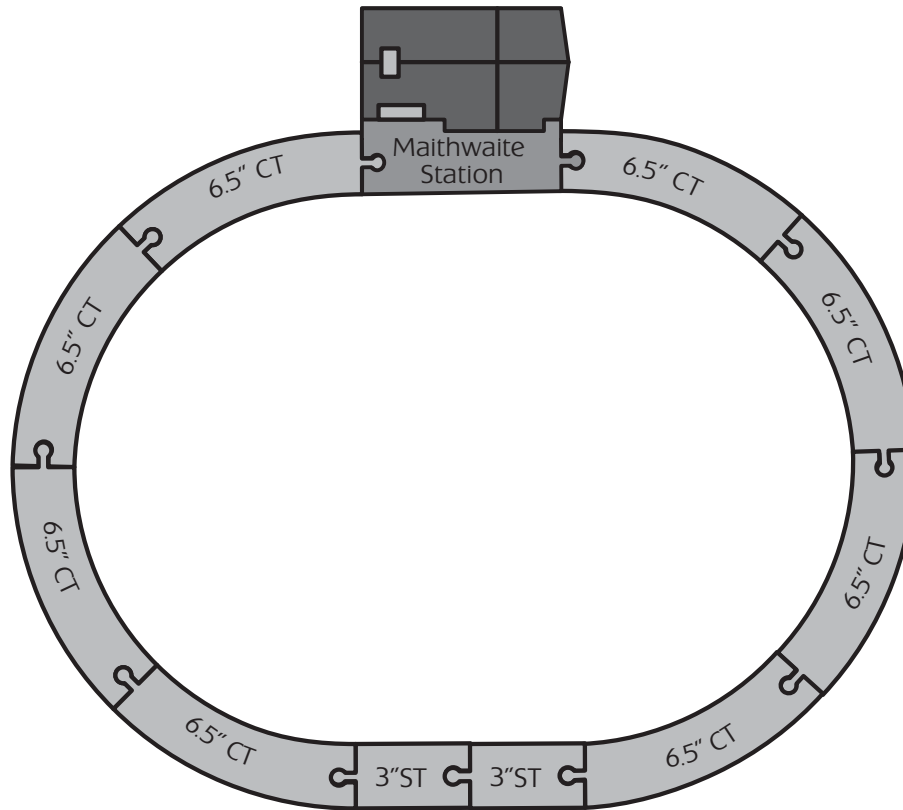

HiT entertainment

© Gullane (Thomas) Limited 2009
 © 2009 HiT Entertainment Limited. HiT and the HiT Logo are trademarks of HiT Entertainment Limited.

Questions? Comments?
 Contact Consumer Care
www.LearningCurve.com
 800-704-8697

© 2009 Learning Curve Brands Inc,
 Oak Brook, Illinois 60523-1940 USA.
 Hembury House, Pynes Hill, Rydon Lane, Exeter, EX2 5AZ UK.
 Distributed in the UK by RC2 UK.

To Replace Batteries:

- Locate battery box on underside of Great Waterton Station.
- Using a Phillips-head screwdriver (not included), remove battery box cover and set aside .
- Replace the old batteries with three (3) new 1.5V AAA batteries.
- Replace battery box cover and tighten screw.

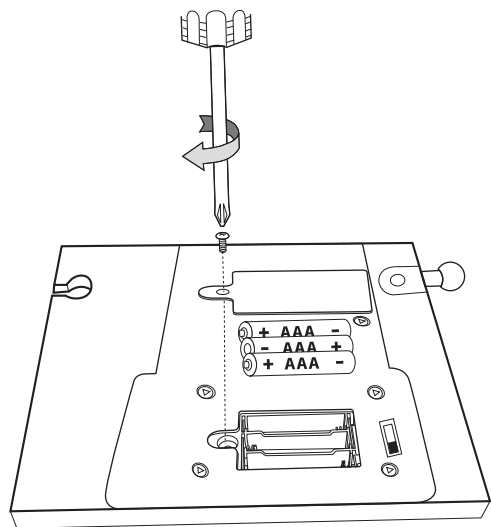

Battery Tips:

- Always install and change batteries under adult supervision.
- Non-rechargeable batteries are not to be recharged.
- Rechargeable batteries are only to be charged under adult supervision.
- Only use batteries of the same or equivalent type as recommended.
- Insert batteries with the correct polarity.
- Remove exhausted batteries from the toy and dispose of properly.
- Do not short-circuit the supply terminals.
- Do not mix different types of batteries or new-and-used batteries.
- Do not mix alkaline, standard (carbon-zinc) or rechargeable (nickel-cadmium) batteries.
- Rechargeable batteries are to be removed from the toy before being charged.

FCC Statement:

This device complies with Part 15 of the FCC Rules. Operation is subject to the following two conditions: (1) This device may not cause harmful interference, and (2) this device must accept any interference received, including interference that may cause undesired operation.

NOTE: This equipment has been tested and found to comply with the limits for a Class B digital device, pursuant to Part 15 of the FCC rules. These limits are designed to provide reasonable protection against harmful interference in a residential installation. This equipment generates, uses and can radiate radio frequency energy and, if not installed and used in accordance with the instructions, may cause harmful interference to radio communications. However, there is no guarantee that interference will not occur in a particular installation. If this equipment does cause harmful interference to radio or television reception, which can be determined by turning the equipment off and on, the user is encouraged to try to correct the interference by one or more of the following measures:

- Reorient or relocate the receiving antenna.
- Increase the separation between the equipment and receiver.
- Connect the equipment into an outlet on a circuit different from that to which the receiver is connected.
- Consult the dealer or an experienced radio/TV technician for help.

Warning: Changes or modifications to this unit not expressly approved by the party responsible for compliance could void the user's authority to operate the equipment.

Caution: For best electronic performance, do not play with the toy on a metal surface. Under an environment with electrostatic discharge, the toy may stop working. It requires the user to re-install the battery which will reset the toy.

In the European market, the dustbin symbol indicates that batteries, rechargeable batteries, button cells, battery packs, etc. must not be put in the household waste. Batteries containing hazardous substances are harmful to the environment and to health. Please help to protect the environment from health risks and tell your children to dispose of batteries properly and take them to the local collecting points. Batteries are recycled safely in this manner. The chemical symbols Hg (Mercury), Cd (Cadmium) or Pb (Lead) shown on the dustbin symbol indicates that the content of that chemical exceeds a certain limit.